

ZOOMLION

**NEW**

# ROUGH TERRAIN

ELECTRIC ARTICULATING BOOM LIFTS

## ZA20JERT-Li

Comply with ANSI/CSA Standard

### HIGHLIGHTS

- ▶ Provide greater work height of 21.38m and lift capacity of 250kg/360kg than competitor
- ▶ Fast lift system directly lowers the boom from the highest position to the ground, no need to fold the boom to improve work efficiency
- ▶ Accurate and efficient traveling AC drive system and on-board motion AC drive system provides strong power, stable control and maintenance-free motor
- ▶ Independent auxiliary power system for more secure application
- ▶ Large reduction ratio reducer provides stronger gradeability
- ▶ Large-capacity lithium battery features long-lasting battery life, and number of charge and discharge cycles reaches 2500 times, the whole life cycle is maintenance-free, and a 5-year warranty is provided

### FEATURES

#### Standard Features

- Proportional control
- All motion alarm
- Flashing beacon
- Self-closing entry gate
- Emergency descent system
- Emergency stop button
- Auto-leveling system
- On-board diagnostic system
- Over tilt protection system
- Oscillating axle

- Load sensing system
- 4.3' LED display
- Horn
- Anti-crushing device
- Fast lowering function

#### Accessories & Options

- Platform light
- AC power to platform
- Airline to platform
- 2.44×0.91m/8ft×2.98ft work platform
- Non-marking tire
- Battery management system (ZA20JERT-Li Only)

**ACCESS WITH ZOOMLION GREEN**

Phone: 0086(731)-88353680 0086(731)-88250971  
E-mail: awp@zoomlion.com

Add: 701 Xulong Nan Lu, Xiangjiang New District, Changsha, Hunan, China  
Web: www.zoomlion-access.com



# ROUGH TERRAIN ELECTRIC ARTICULATING BOOM LIFTS

## **NEW** ROUGH TERRAIN

### **ZA20JERT-Li** Comply with CE/ANSI/CSA Standard

| Model                    | ZA20JERT                    |             | ZA20JERT-Li                 |             |
|--------------------------|-----------------------------|-------------|-----------------------------|-------------|
|                          | Imperial                    | Metric      | Imperial                    | Metric      |
| <b>Size</b>              |                             |             |                             |             |
| Work Height              | 70ft 1in                    | 21.38m      | 70ft 1in                    | 21.38m      |
| Platform Height          | 63ft 7in                    | 19.38m      | 63ft 7in                    | 19.38m      |
| Horizontal Outreach      | 39ft 8in                    | 12.1m       | 39ft 8in                    | 12.1m       |
| Up and Over Height       | 27ft 1in                    | 8.25m       | 27ft 1in                    | 8.25m       |
| A - Stowed Length        | 28ft 10in                   | 8.8m        | 28ft 10in                   | 8.8m        |
| B - Stowed Width         | 8ft 1in                     | 2.46m       | 8ft 1in                     | 2.46m       |
| C - Stowed Height        | 8ft 3in                     | 2.52m       | 8ft 3in                     | 2.52m       |
| D - Platform Length      | 8ft                         | 2.44m       | 8ft                         | 2.44m       |
| E - Platform Width       | 3ft                         | 0.91m       | 3ft                         | 0.91m       |
| F - Wheelbase            | 8ft 3in                     | 2.52m       | 8ft 3in                     | 2.52m       |
| G - Ground Clearance     | 1ft 4in                     | 0.4m        | 1ft 4in                     | 0.4m        |
| <b>Performance</b>       |                             |             |                             |             |
| Platform Capacity        | 550 lb/793 lb               | 250kg/360kg | 550 lb/793 lb               | 250kg/360kg |
| Drive Speed              | 3.79 mph                    | 6.1km/h     | 3.23 mph                    | 5.2km/h     |
| Gradeability             | 45%                         |             | 45%                         |             |
| Axles Oscillation        | 8in                         | 0.20m       | 8in                         | 0.20m       |
| Turning Radius (Inside)  | 9ft 1in                     | 2.78m       | 9ft 1in                     | 2.78m       |
| Turning Radius (Outside) | 18ft                        | 5.49m       | 18ft                        | 5.49m       |
| Turntable Swing          | 360° continuous             |             | 360° continuous             |             |
| Platform Rotation        | ±90°                        |             | ±90°                        |             |
| H-Tail Swing             | 2ft 1in                     | 0.64m       | 2ft 1in                     | 0.64m       |
| Max. Working Slope       | 3°/5°                       |             | 3°/5°                       |             |
| Max. Wind Speed          | 28mph                       | 12.5m/s     | 28mph                       | 12.5m/s     |
| <b>Power</b>             |                             |             |                             |             |
| Battery                  | 24×2V/440Ah                 |             | 48V/315Ah Li-ion battery    |             |
| Charger                  | 48V/60A                     |             | 48V/60A                     |             |
| Drive Motor              | AC 32V                      |             | AC 32V                      |             |
| Lift Motor               | AC 32V                      |             | AC 32V                      |             |
| Auxiliary Power          | 12V DC Electrical pump      |             | 12V DC Electrical pump      |             |
| Hydraulic Tank Capacity  | 19.8 (us gal)               | 75L         | 19.8 (us gal)               | 75L         |
| <b>Tire</b>              |                             |             |                             |             |
| Type                     | 33×12 D610 Foam-filled tire |             | 33×12 D610 Foam-filled tire |             |
| <b>Weight</b>            |                             |             |                             |             |
| Gross                    | 20392 lb                    | 9250kg      | 20392 lb                    | 9250kg      |

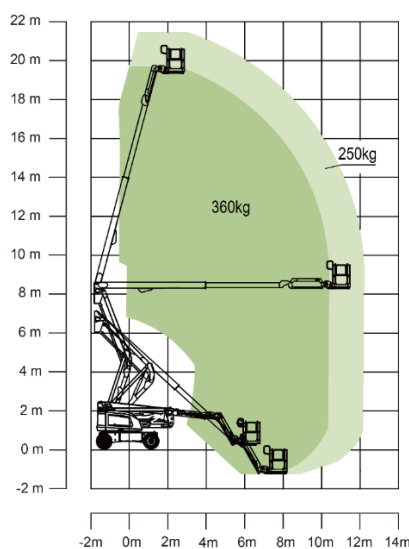
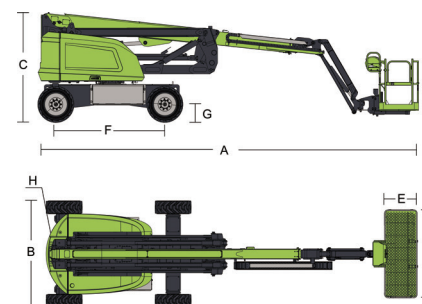

Range of Motion ZA20JERT/ZA20JERT-Li